

# CURRENT TRANSFORMER

Model 352R

Window Diameter 3.19"

**APPLICATION:**  
Relaying and metering.

**FREQUENCY:**  
50-400 Hz.

**INSULATION LEVEL:**  
0.6 kV, BIL 10 kV full wave.

REGULATORY AGENCY APPROVALS



Manufactured to meet the requirements of ANSI/IEEE C57.13.  
Classified by U.L. in accordance with IEC 44-1.

**CONTINUOUS THERMAL CURRENT RATING FACTOR:**  
1.33 at 30°C amb., 1.0 at 55°C amb.

- Secondary terminals are brass screws No. 10-32 with one flatwasher and lockwasher.
- Window opening to accommodate 3.00" X 0.50" bus, horizontal or vertical.
- Approximate weight 18 lbs.

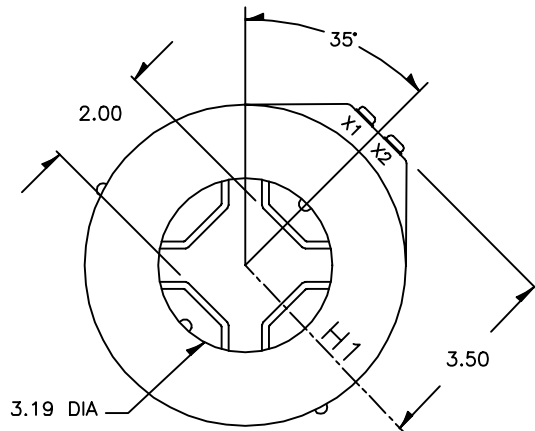
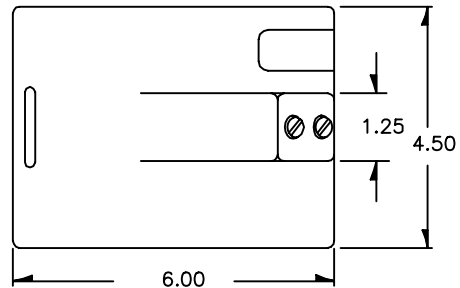
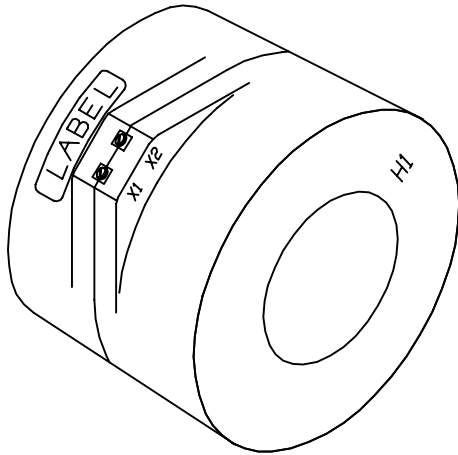

EXCITATION CURVE

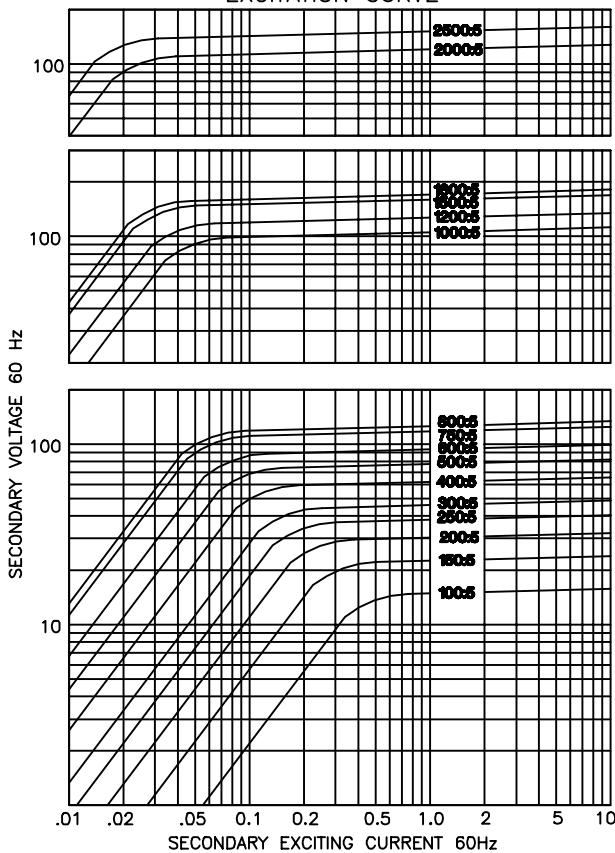

CATALOG NUMBER	CURRENT RATIO	RELAY CLASS	ANSI METERING CLASS AT 60 Hz					SECONDARY WINDING RESISTANCE (OHMS @ 75 °C)
			B0.1	B0.2	B0.5	B0.9	B1.8	
352R-101	100:5	-	1.2	2.4	4.8	-	-	0.062
352R-151	150:5	C 10	1.2	1.2	2.4	4.8	-	0.094
352R-201	200:5	C 20	0.6	1.2	2.4	2.4	-	0.125
352R-251	250:5	C 20	0.6	0.6	1.2	2.4	4.8	0.156
352R-301	300:5	C 20	0.3	0.6	1.2	1.2	2.4	0.187
352R-401	400:5	C 50	0.3	0.3	0.6	1.2	2.4	0.250
352R-501	500:5	C 50	0.3	0.3	0.6	0.6	1.2	0.312
352R-601	600:5	C 50	0.3	0.3	0.3	0.6	0.6	0.375
352R-751	750:5	C 20	0.3	0.3	0.3	0.6	0.6	0.468
352R-801	800:5	C 20	0.3	0.3	0.3	0.6	0.6	0.500
352R-102	1000:5	C 50	0.3	0.3	0.3	0.3	0.6	0.583
352R-122	1200:5	C 50	0.3	0.3	0.3	0.3	0.3	0.700
352R-152	1500:5	C 50	0.3	0.3	0.3	0.3	0.3	0.875
352R-162	1600:5	C 50	0.3	0.3	0.3	0.3	0.3	0.933
352R-202	2000:5	C 20	0.3	0.3	0.3	0.3	0.3	1.092
352R-252	2500:5	C 20	0.3	0.3	0.3	0.3	0.3	1.365